

# Optical Engineering Curriculum

Name: \_\_\_\_\_

ID: \_\_\_\_\_

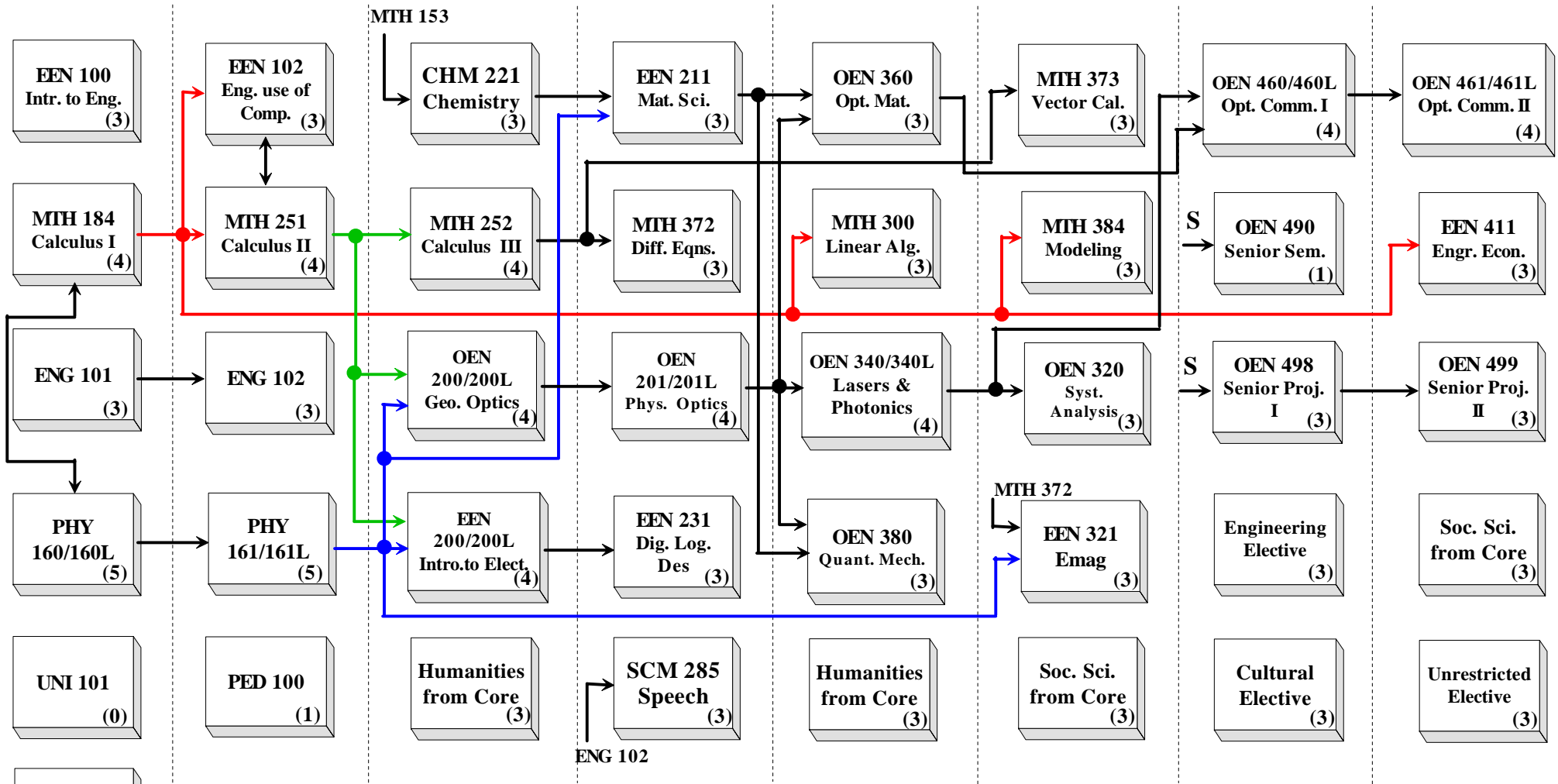

**S = Senior Standing**  
**\* = Courses satisfy the University cultural elective requirement**  
**#\* = Do not register Freshmen or Sophomores in these classes**

- Humanities (6 Semester Hours)**
- HUM 210 Humanities of Western World
  - HUM 211 Humanities: A Cross Cultural Exploration
  - ENG 207 Literature of the Western World
  - FIA 201 Basic Art Appreciation
  - MUS 301 Music Appreciation
  - #\*ENG 383 African-American Literature
  - \*FIA 170 African and African-American Art
  - #\*MUS 370 African-American Music

- Social Science (6 Semester Hours)**
- SOC 101 Introduction to Social Sciences
  - HIS 100 History of World Civilization
  - HIS 101 History of World Civilization
  - HIS 102 United States History to 1877
  - HIS 103 United States History since 1877
  - #\*HIS 335 African-American History to 1865
  - #\*HIS 336 African-American History since 1865
  - #\*HIS 370 African History and Culture (Part 1)
  - #\*HIS 371 African History and Culture (Part 2)
  - #\*SOC237 Cultural and Racial Minorities
  - #\*POS 315 Blacks in the American Political Process
  - #\*PSY 340 Psychology of African Americans